

# Diamond Power® Series II — Multi-Probe Electronic Level Indicator

The Diamond Power® Series II multi-probe electronic level indicator (ELI) from Babcock & Wilcox (B&W) was developed to satisfy basic level indication needs utilizing vacuum-brazed probes for boiler drum, feedwater heaters and other liquid level applications. The multi-probe system consists of three major components: the column with probes, the detection and verification unit (D&V), and the remote display.

The conductivity probe with vacuum-brazed insulators has been proven reliable for many years of service. The Swagelok® metal-to-metal seal of the multi-probe system provides leak-proof installation in the column.

Operation of the system is based on measurement of the difference in resistance between water and steam, which is compared with a known reference resistor. The signal output to the probes is a symmetrical source wave  $\pm 5$  VDC current which precludes electroplating of the probe. The ELI measures the returning signal to indicate 'water' or 'steam.'

## Features

- Solid-state electronics and two-color display
- Solid-state output to drive up to three remote displays
- NEMA 4X (IP65) enclosed detection and verification unit
- 10 amp power relay contact output for each probe to control trips and alarm
- Three-way adjustment for water conductivity
- Standard remote customized LED display panel

## Benefits

- Electronic self-monitoring and indication in the D&V unit; optional probe wire continuity monitor, power supply failure (redundant power supplies), clock (DC detection circuit) failure
- 10 amp power relay contact output for electronic faults
- 10 amp power relay contact output for level fault (water over steam)
- On board water detection indication in the D&V unit

## Applications

**For boiler drum level indication to maintain proper steam drum water level** — If the water level is too low, boiler tubes may be damaged. If the water level is too high, damage to the steam separator or steam turbine from water carry over can occur.



**For high and low pressure feedwater heaters for detection of abnormal high or low levels within the feedwater heater steam section** — The multi-probe ELI provides critical alarm and trip function. If the condensate level in the heater is too high, the heater will not operate at maximum efficiency, and could cause the steam safety valve to open. If too low, steam is discharged directly into the next heater, also reducing efficiency.

The multi-probe ELI was designed to satisfy the 2013 ASME\* Boiler and Pressure Code (Section 1, Para, PG-60) requirement. A multi-probe ELI installed as one of two remote indicators along with the required gauge is shown.

A duplicate multi-probe ELI can be used as the second remote indicator. The column with probes provides remote indication and also acts as a stabilizer for the gauge.

*\* Water column to be certified in accordance with ASME Section 1*

## Availability

The Multi-Probe column is custom manufactured to provide the most accurate indication for any application. The electronic system in the D&V unit is connected to 5, 8, 10, 12 or more probes that are spaced to indicate water and steam through a desired operating range.

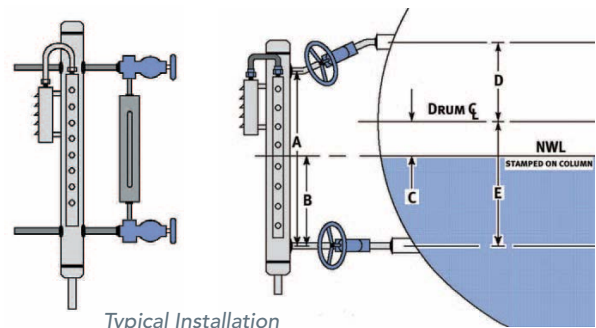

Typical Installation

(Continued on reverse side)

## Specifications

Power Source	120 or 240 VAC, single phase, 50-60 Hz, 1/2 -1/4 A
Relay Contact Ratings	10A @ 120 VAC, 8 A @ 24 VDC, 1/3 HP @ 120 VAC
Supply Current	1/4 and 1/8 A
Column	Ratings – up to 3000 psi (207 bar) and 1200F (649C) maximum. Materials – Carbon Steel, Stainless Steel and Chrome Moly
Enclosure	NEMA 4X (IP66)
Conductivity Capability	0.5 micro mho
Electronic Unit to Column Distance	0.5 to 4 micro mho – 65 ft (20 m) 4 to 25 micro mho – 165 ft (50 m) Above 25 micro mho – 500 ft (150 m)

## Options

### To customize unit for individual applications:

- Door mounted local display
- Small remote display (reduced size for desk mounting)
- Dual power source
- Adjustable trip/alarm time delay
- In service test switch
- Additional remote displays
- Column mounted pre-wired junction box
- Wire continuity fault detection
- Zener diode barrier for hazardous applications
- 2000 and 3000 psi (138 and 207 bar) FM approved systems
- 16, 20, 24 (and up) probe systems

**IMPORTANT:** The 4-20 mA serial module produces a smooth continuous signal from the discrete probe levels. However, since the probe indications are “point” measurements, it is not intended for level control. It should only be used for remote indication or level recording.

### 4-20mA analog output for level indication or trend recording

- Intelligent I/O card designed to provide an isolated analog signal
- Integrity is provided via watchdog logic
- Has a 3-wire RS-485 Serial Output link to drive the multi-probe display indicators
- Multiple remote displays can be daisy-chained together
- Analog module powered from 3000M electronics (default) or from external power source (optional)



**Ordering:** Use B&W form SP-652 to list the particular equipment design specifications, configurations, and options.

*Electronic Level Indicator*

## Babcock & Wilcox

20 South Van Buren Avenue  
Barberton, Ohio, U.S.A. 44203  
Phone: +1 330.753.4511

[www.babcock.com](http://www.babcock.com)     

The information contained herein is provided for general information purposes only and is not intended nor to be construed as a warranty, an offer, or any representation of contractual or other legal responsibility.

Diamond Power is a trademark of The Babcock & Wilcox Company.

Swagelok is a trademark of Swagelok Company.



ENERGY | ENVIRONMENTAL

Established in 1867, Babcock & Wilcox is a global leader in advanced energy and environmental technologies and services for the power, industrial and renewable markets, with operations, subsidiaries and joint ventures worldwide.

For more information or to contact us, visit our website at [www.babcock.com](http://www.babcock.com).