

# DynaDischarger® Furnace Ash Extractor

VØLUND® SYSTEMS TECHNOLOGY

High availability  
with reduced risk of  
unplanned outages

Proper maintenance and operation of your plant is essential for achieving its full potential and performance. Babcock & Wilcox Renewable (B&W) offers a wide range of Vølund® technology and service solutions that can upgrade, improve and simplify operation and maintenance while helping reduce downtime and save money. Our DynaDischarger® furnace ash extractor is designed to improve performance, lengthen time between normal maintenance, reduce unplanned outages, and increase worker safety.

The DynaDischarger ash extractor can be designed for new boiler systems or retrofit onto existing boilers. Installation on existing units is typically completed during normal service shutdown periods.

A single, unplanned discharger outage takes about 75 hours. The DynaDischarger furnace ash extractor reduces the risk of such outages.

## Features

- **Increased overall size** to handle larger objects. The new discharger has a longitudinal opening of 1200 mm, an increase of 200 mm from our standard discharger. It is available in widths of 2000 mm or 3000 mm.
- The **retractable shear wall** of the discharger outlet is adjustable from 1000 mm during normal operation to 1200 mm to accommodate larger objects.
- **Leg-mounted design** reduces the load on the steel structure of the furnace.
- A **bellow** installed between the hopper and ash discharger provides a gas-tight seal.
- The back-end of the DynaDischarger bottom ash extractor housing is designed with an **inclined bottom and a large valve** to facilitate drainage of water and settled ash.
- When fully retracted, the **discharge ram** is flush with the ash discharger's front wall to reduce the risk of blockage.
- **Refractory-lined dampers** in the top section allows internal access to the discharger through entrance doors without shutting down the plant. The dampers can also be used as a service platform in the ash chute during maintenance.
- A **large inspection door** (610 mm wide X 900 mm high) is located above the outlet. Two additional doors on each side of the chute section improve internal access for clearing debris buildup in the chute and discharger outlet.
- **Easy replacement of the front steel wear plate** of the discharge ram from inside the extractor.
- A **scraper unit** on top of the discharge ram is designed to prevent objects from traveling back into the extractor housing behind the front wall.
- **Ash level sensors** alert operators of an abnormal rise in ash levels to allow timely corrective action.
- Can be installed with **third-party grates**.

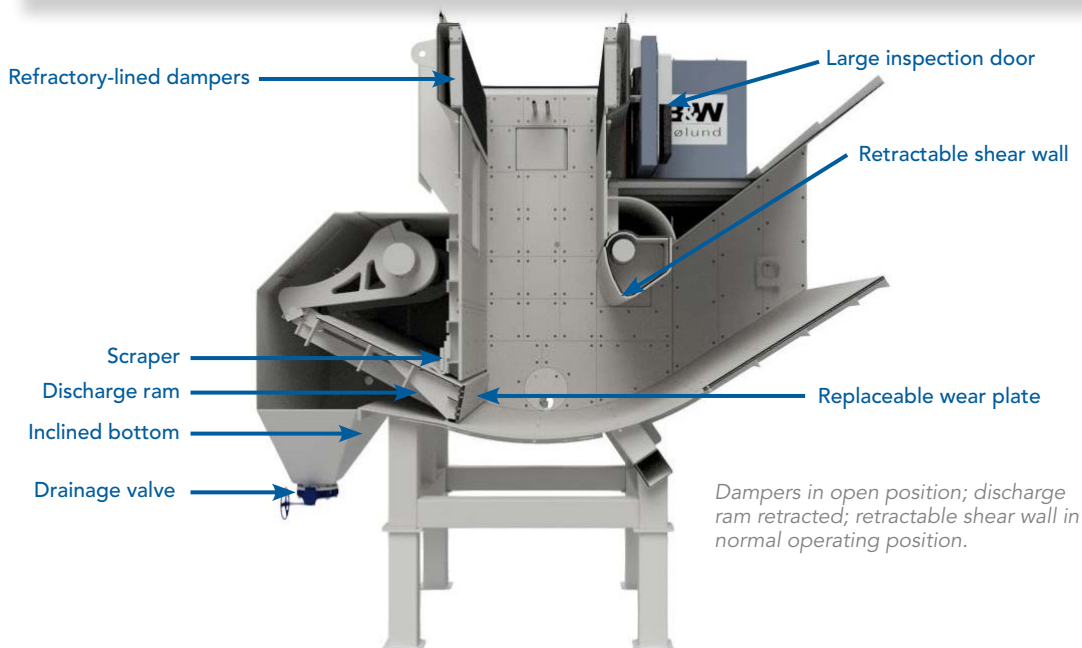

continued ►



Dampers in closed position; discharge ram in forward position; retractable shear wall in raised position.

## Available Options

Standard Offering	Retractable shear wall	Damper	Vølund® safety hatch
20% larger internal cross-section reduces the risk of blockage and downtime	Reduces risk of blockage and downtime even more by allowing an adjustable increase of the outlet height by 20%	Eliminates the need for plant shutdown to remove stuck objects	Allows larger access to objects within the discharger
Withdrawn discharge ram provides more space for the ash and slag and thereby reduces blockage risk		Reduces scaffolding costs when used as a service platform during planned shutdowns	
Wear plate of the discharge ram can be replaced from the inside of the extractor, reducing service costs		Ash level sensors alert operators of an abnormal rise in ash levels to allow timely corrective action	
Scrapers on top of the discharge ram reduces slag and unburned waste in the rear waterbox, reducing service costs	<p><b>Benefits</b></p> <p>The DynaDischarger® furnace ash extractor is configurable to your needs and application. A range of options are available to provide additional benefits not available with other designs.</p>		
Earthquake resistant due to support steel			
Reduced loads on steel structure			

### Babcock & Wilcox

Dybendalsvaenget 3  
2630 Taastrup  
Denmark  
Phone: +45 76.14.34.00

[www.babcock.com/renewable](http://www.babcock.com/renewable)    

The information contained herein is provided for general information purposes only and is not intended nor to be construed as a warranty, an offer, or any representation of contractual or other legal responsibility.

Vølund and DynaDischarger are trademarks of The Babcock & Wilcox Company or its affiliates.



RENEWABLE | ENVIRONMENTAL | THERMAL

Established in 1867, Babcock & Wilcox is a global leader in renewable, environmental and thermal technologies and services for power and industrial applications.

For more information or to contact us, visit our website at [www.babcock.com](http://www.babcock.com).