

B&W Parts, Services and Programs for CE-Type Pulverizers/Mills

Babcock & Wilcox (B&W) applies our vast experience and knowledge of roll wheel and ball-and-race pulverizers to provide quality replacement parts, services and inventory management programs to Combustion Engineering (CE)-type pulverizers.

Since 1867, B&W has set the standard for proven high availability, reliability and low maintenance on its boilers, pulverizers and other steam generating and auxiliary equipment. We remain invested in coal and will continue to provide quality products and services to keep the fleet of coal-fired power generators operating reliably, efficiently and with high availability.

Our approach goes well beyond simple in-kind replacement and repair services. We provide engineered solutions and upgrades based on thorough inspection of your equipment. Our rebuilt assemblies can run better and last longer reducing maintenance and downtime.

Engineered pulverizer parts and upgrades are designed to deliver performance and reliability which provide enhanced operation and value to your plant's capital investments, regardless of original equipment manufacturer (OEM).

B&W supports pulverizers/mills manufactured by CE and others, including:

- CE/Raymond deep bowl mills
- CE shallow bowl mills
- Schenck Raymond roller mills

Mill services from our regional centers of excellence

- Journal rebuilds and exchanges
 - assemblies rebuilt to original OEM specs
 - thorough inspection reports
 - standard parts in-stock for quick turnaround
 - exchange journals stocked in various sizes for immediate delivery
- Gearbox rebuilds
- Replacement rolls
 - cast steel core with overlay options
 - Xwin® material
- Assured Stock Program® (ASP®) inventory management
- Technical support services – rebuild/repair support expertise, troubleshooting, testing and tuning
- Mill maintenance and operator training

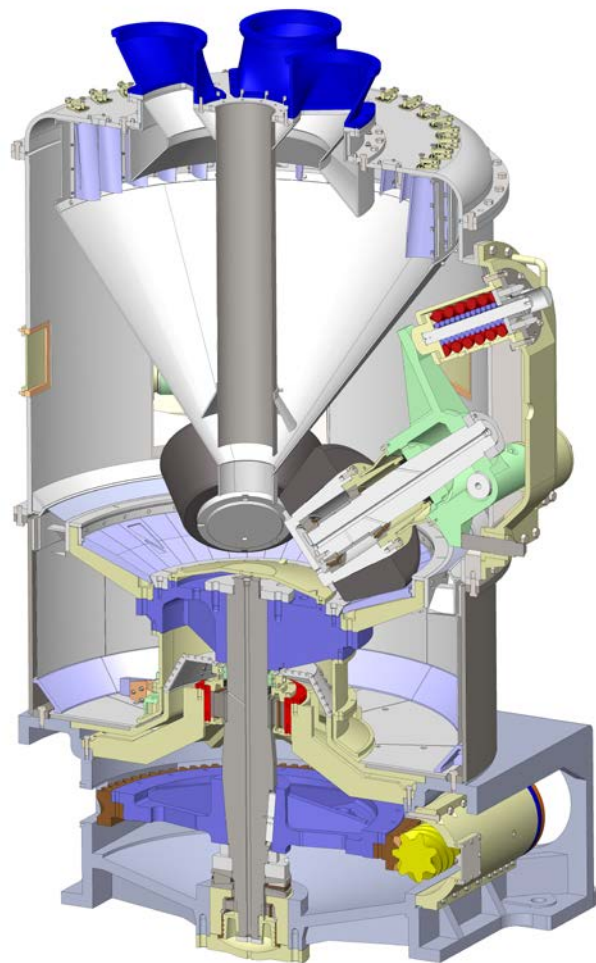

continued ▶

Mill replacement parts

- Vane wheel assembly (upgrade from OEM design)
- Upper and lower bowl skirt (upgrade from OEM design)
- Standard and extended life journal bearing assembly (upgrade from OEM design)
- Journal head liner assembly
- Grinding rolls – ribbed, weld overlay, high chrome, Xwin material technology
- Grinding segments – weld overlay, high chrome, Xwin material technology
- Trunion assembly
- Steel bowl
- Mill liners
- Millside access doors (upgrade from OEM design)
- Gearbox worm gear (upgrade from OEM design)
- Main shaft
- Classifier (multi-piece)

Strategic alliance with wear parts expert

Through a strategic alliance, B&W provides advanced coal pulverizer replacement parts from Magotteaux, a leading supplier of high wear, severe duty castings and differentiated wear solutions.

As a leader in process optimization solutions for high abrasion extracting industries, Magotteaux provides low chrome, high chrome, ceramic, and its own proprietary Xwin material technology. Xwin technology combines the extreme high hardness of ceramic with the mechanical properties of high chromium metal for maximum wear resistance and wear life. Magotteaux's Xwin technology is available for grinding rolls and grinding segments.

Advantages of the Xwin technology include:

- extended running life
- increased time between maintenance cycles
- longer consistency of grinding profiles
- extended duration of optimal pulverizer capacity and fineness
- reduced power consumption



Assured Stock Program[®] inventory management

B&W's Assured Stock Program inventory management system is a proven strategy designed to enhance the purchasing and inventory functions of both utility and industrial customers.

The Assured Stock Program inventory management system focuses on planning specific material requirements and minimizing your inventory levels. The customized program reduces the overall cost of obtaining parts and components, while maintaining and improving power generation reliability and availability.

For more information, contact your regional B&W sales or service office, call us at 1-800-354-4400 within the United States, or +1 330-860-1460 outside of the U.S., or send an email to oemparts@babcock.com.

Babcock & Wilcox

1200 E Market Street, Suite 650
Akron, Ohio, U.S.A. 44305
Phone: +1 330.753.4511

www.babcock.com    

The information contained herein is provided for general information purposes only and is not intended nor to be construed as a warranty, an offer, or any representation of contractual or other legal responsibility.

Assured Stock Program and ASP are trademarks of The Babcock & Wilcox Company.

Xwin is a trademark of Magotteaux International.
Raymond is a trademark of Schenck Process LLC.



RENEWABLE | ENVIRONMENTAL | THERMAL

Established in 1867, Babcock & Wilcox is a global leader in renewable, environmental and thermal technologies and services for power and industrial applications.

For more information or to contact us, visit our website at www.babcock.com.