



Gas Horn Ignitor for Corner-Fired Boiler Applications

The Babcock & Wilcox Company (B&W) is the exclusive source in the United States for the Fossil Power Systems (FPS™) gas horn ignitor equipment. The FPS gas horn ignitor equipment is a careful integration of electrical-mechanical components optimizing performance in areas of ignition reliability, combustion, flame stability and flame monitoring.

The FPS gas horn ignitor provides up to 20 million Btu per hour heat input. Each ignitor is supplied with a mounting plate and gasket custom designed to mount on the existing ignitor bolt arrangement, making ignitor installation very simple.

The ignitor is shop assembled onto the mounting plate so that the ignitor internal components insert through the windbox air chamber and into the ignitor horn. The ignitor assembly can be easily withdrawn for maintenance. Ignitor dimensions are determined from the burner arrangement drawing.

The gas horn ignitor requires primary air for combustion sourced either from the windbox or from an external air supply. For most installations, the existing air supply provides an ideal source.

The internal guide tube assembly places a fuel/air mixing plate (eddy plate) at a precise location in the horn. This in turn accurately positions the gas nozzle, spark plug and the SunSpot flame rod. The fuel/air mixing at this specially designed plate serves as the initial point of ignition and creates an environment for flame stability.

The FPS gas horn ignitor features 3-stage ignition. Initially, gas from small bleed holes is ignited by the spark plug. Second

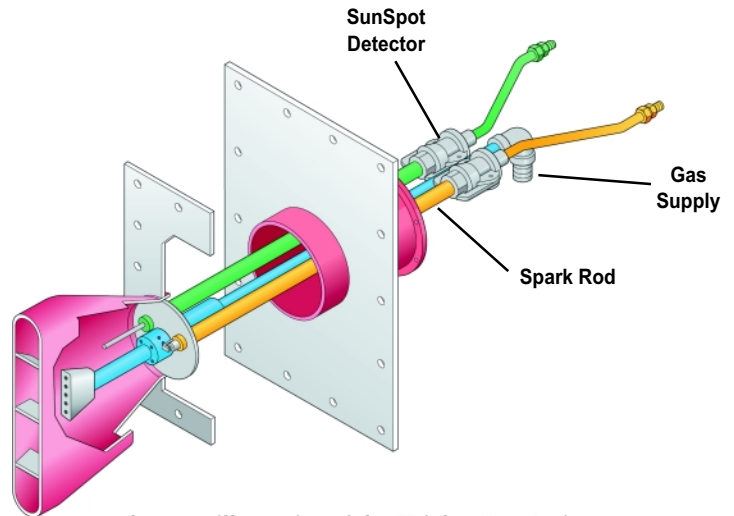

Cutaway illustration of the FPS Gas Horn Ignitor

stage ignition takes place just behind the main gas nozzle, and the final stage is ignition of the main fuel flow from the gas nozzle. This staged ignition creates a stable self-sustaining flame.

A turbulent, fan-shaped flame is created as the flame exits the horn propelled by the differential air pressure between the combustion air source and the furnace. The well directed blow torch flame penetrates the main fuel stream for a positive light-off.

Flame Detector

The FPS gas horn ignitor is equipped with the integral SunSpot flame detector. The SunSpot flame detection system relies on ionization of gases in the combustion process.

Construction and placement of the SunSpot flame rod assembly is similar to the spark assembly. The tip extension on the flame-sensing probe (flame rod) intersects the ignitor flame envelope.

Gas ionization in the ignitor flame creates current flow from the SunSpot electronics down the

flame rod assembly and through the flame envelope to the ignitor horn (i.e., to ground).

The conductivity of the burning flame gas is not constant, changing as the flame flickers. The SunSpot proves flame only when both conductivity and this inherent frequency component are sensed.

The SunSpot is factory calibrated for the expected performance of the ignitor. Advantages of the SunSpot include:

- Discrete flame detection
- No periodic maintenance requirement
- No field calibration
- No delicate optics to break or get dirty

It is critical to have reliable flame detection on ignitors. Applications where single flame scanners monitor both main flame and ignitor flame can be significantly improved with discriminating flame sensing devices like the SunSpot.

(Continued on reverse side)

Ignitor Peripherals

Each FPS gas horn ignitor is supplied with the following environmentally sealed peripheral components:

- High voltage (10,000VAC) ignition transformer in a NEMA 4 enclosure
- SunSpot flame detector electronic module
- Gas hose with swivel connector
- (2) Brass braided flex conduit assemblies for ignitor electrical connections (flame detector and spark)
- Ignitor mounting plate with gasket

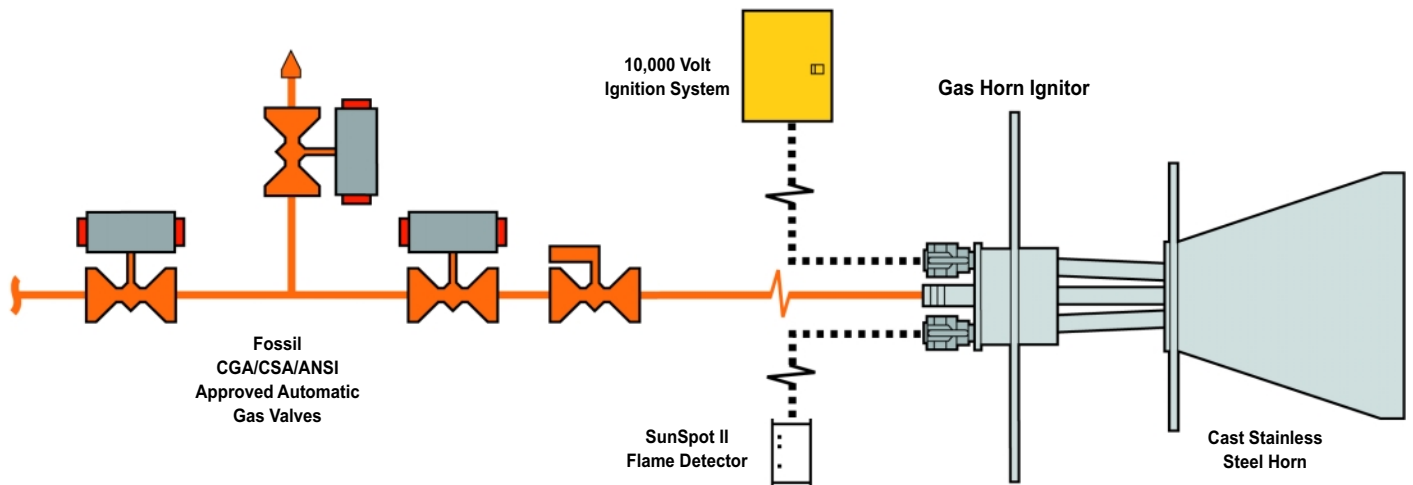

Typical Natural Gas Fuel Schematic

While others may use the Babcock name, we are the original Babcock & Wilcox with more than 135 years of experience in engineering, constructing and servicing steam generating systems. Insist on us by name.

For more information, or a complete listing of our sales and service offices worldwide, call 1-800-BABCOCK (222-2625) in North America. Outside North America, call (330) 753-4511 or fax (330) 860-1886 (Barberton, Ohio, USA). Or access our Web site at www.babcock.com.



B&W and its affiliates have offices in the following locations:

United States of America:

Atlanta, Georgia
 Barberton, Ohio
 Charlotte, North Carolina
 Chicago (Downers Grove), Illinois
 Cincinnati, Ohio
 Dallas, Texas
 Denver (Sheridan), Colorado
 Fairfield, New Jersey
 Houston, Texas
 Kansas City, Missouri
 Mt. Holly, New Jersey
 San Francisco (Vacaville), California
 St. Petersburg, Florida

Canada:

Cambridge, Ontario
 Edmonton, Alberta
 Montreal, Quebec
 Saint John, New Brunswick
 Vancouver (Richmond), British Columbia

Denmark: Esbjerg

Indonesia: Jakarta

People's Republic of China: Beijing

Powering the World Through Teamwork and Innovation®

The information contained herein is provided for general information purposes only and is not intended or to be construed as a warranty, an offer, or any representation of contractual or other legal responsibility.

Powering the World Through Teamwork and Innovation is a trademark of The Babcock & Wilcox Company. FPS is a trademark of Fossil Power Systems, Inc.